

Hot Half Ordering Procedure

To order a Hot Half, Mastip requires a completed Quote Request form with the Hot Half section completed.

The following diagram is used on the form and shows which measurements are required.

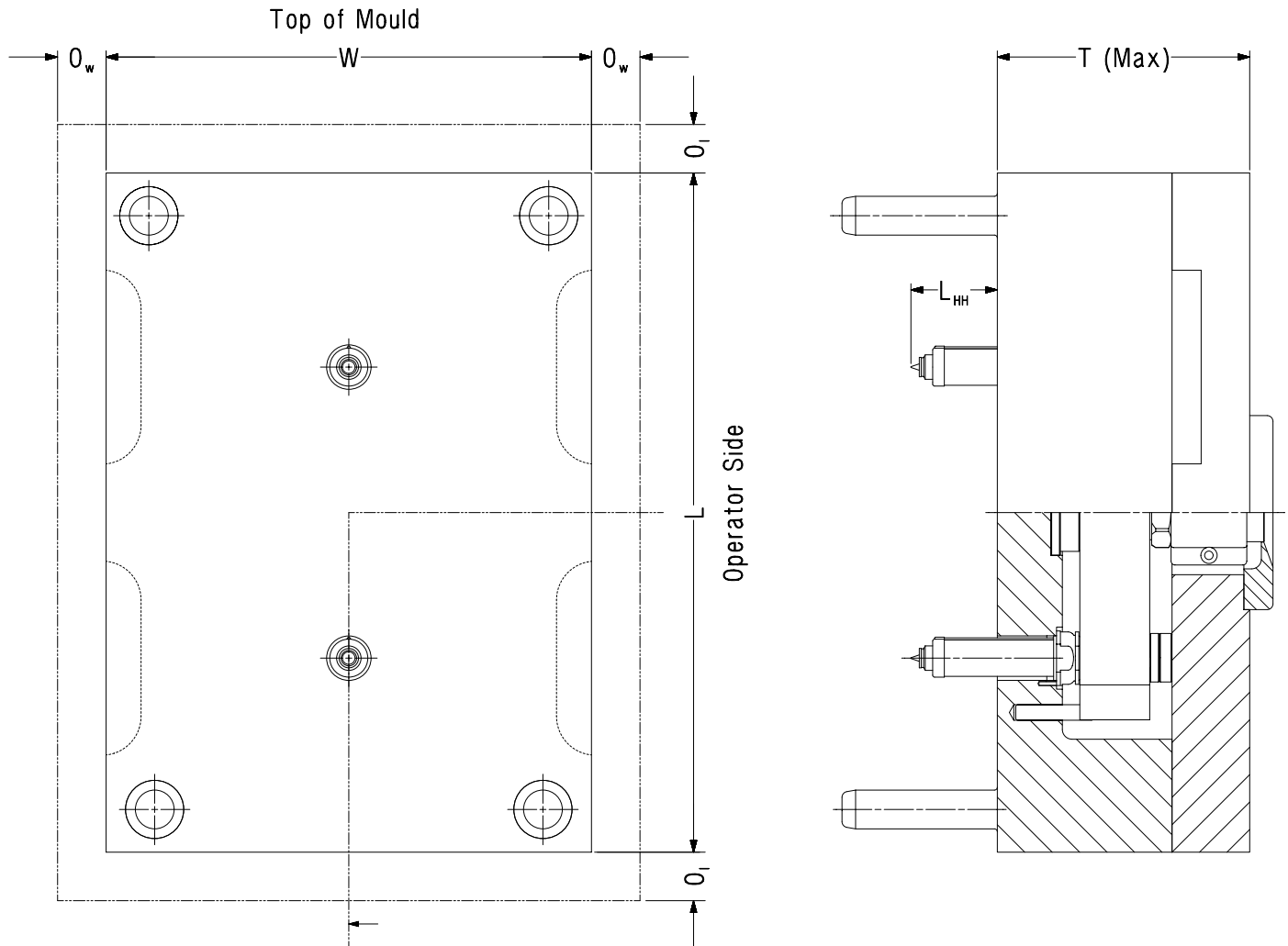

Figure 1: Hot Half dimensions required from customer

Hot Half Benefits

- Warranty
 - All Hot Halves supplied by Mastip carry a 3 Year leak-proof warranty.
- Reduced manufacturing time
 - Hot Half consists of a complete Hot Runner System including manifold plate and back plate manufactured by Mastip, allowing the mould maker time to manufacture the rest of the mould.
 - Hot Half supplied fully wired and assembled.
 - Hot Half designed and manufactured to meet customer's requirements.
- Easy Maintenance
 - Hot Half allows for removal of cavity plate while mould is still in the press.
 - Hot Half construction allows for easy servicing of nozzles, tips, thermocouples and heaters.