

# MJTG09



smart hot runner solutions

[www.mastip.com](http://www.mastip.com)

Tip and Material Grade Availability

Tip (Code)	G1	G2	G5
Multi-hole Torpedo Tip (MJ 09 TT)	×	✓	×

**To order a nozzle assembly:**

Provide the Nozzle Code + Grade  
 (Order example: MJTT09075 G2)

**To order a tip:**

Provide the Tip Code + Grade  
 (Order example: MJ 09 TT G2)

Nozzle Dimensions

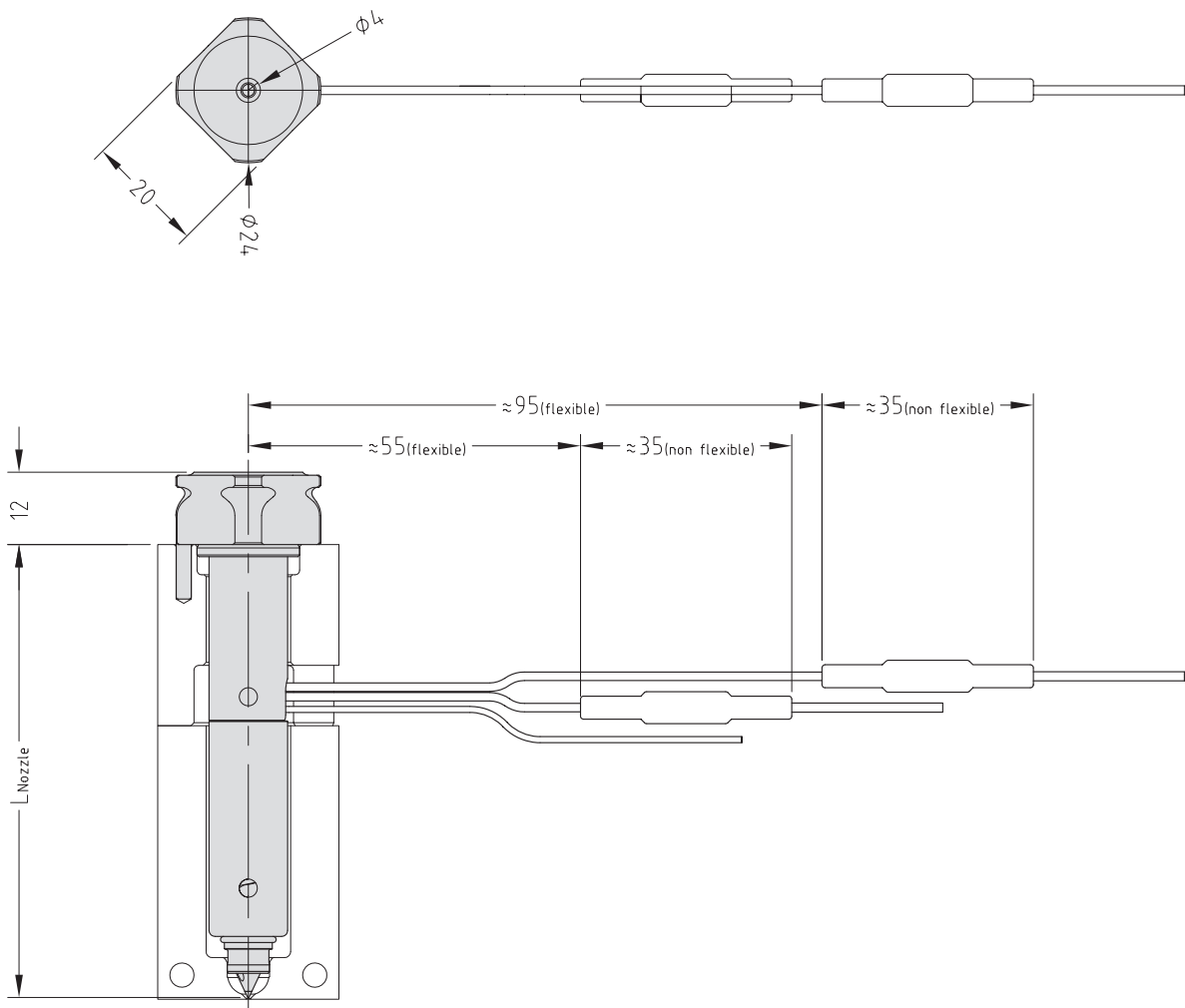



Tip and Material Grade Availability

Tip (Code)	G1	G2	G5
Multi-hole Torpedo Tip (MJ 09 TT+5)	×	✓	×

To order a nozzle assembly:

Provide the Nozzle Code + Grade  
 (Order example: MJTT09075+5 G2)

To order a tip:

Provide the Tip Code + Grade  
 (Order example: MJ 09 TT+5 G2)

Nozzle Dimensions

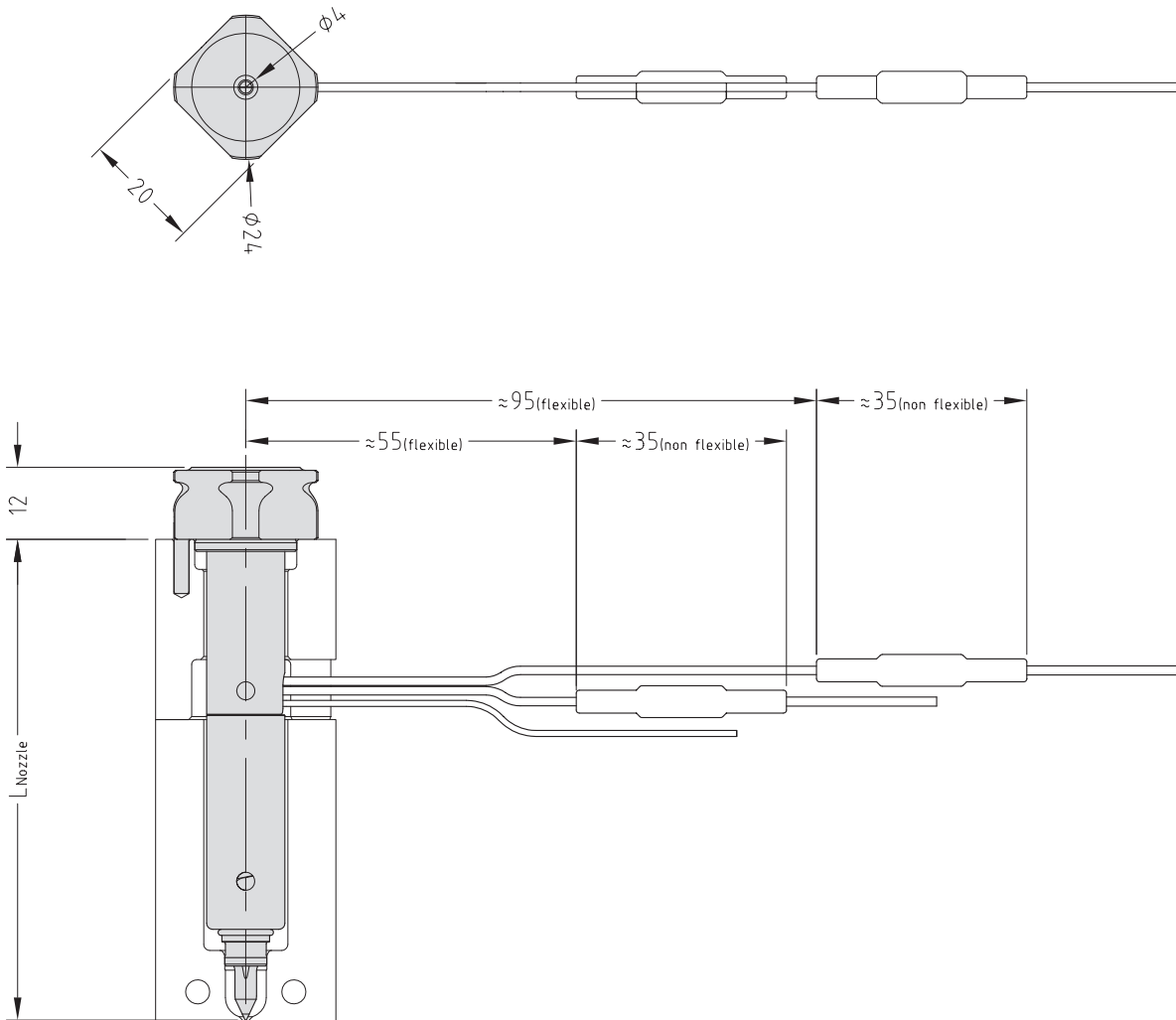

Nozzle Code	L	E@ΔT =200C	E@ΔT =250C
MJTT09075+5	80	0.21	0.26
MJTT09095+5	100	0.26	0.33
MJTT09115+5	120	0.32	0.40
MJTT09130+5	135	0.36	0.46
MJTT09145+5	150	0.40	0.50
MJTT09175+5	180	0.48	0.59

**Front Loading Configuration - Recommended**

$E = L \times 0.0000132 \times (\text{nozzle temp. } ^\circ\text{C} - \text{mould temp. } ^\circ\text{C})$

**Rear Loading Configuration**

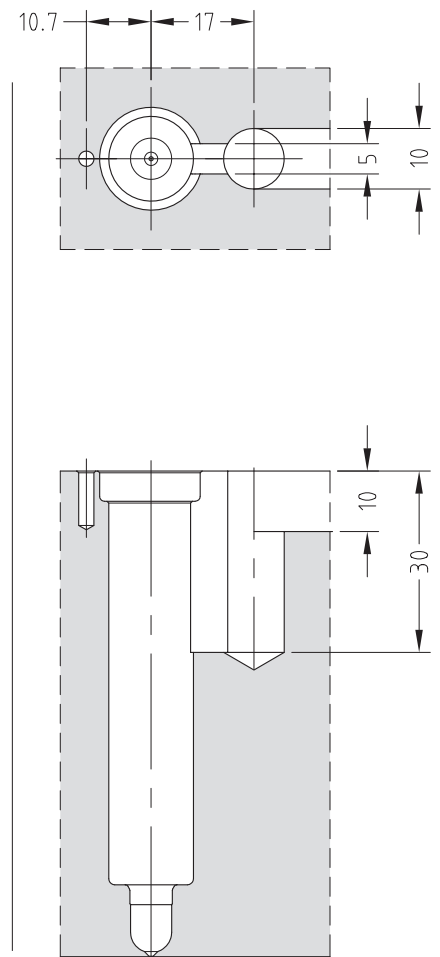
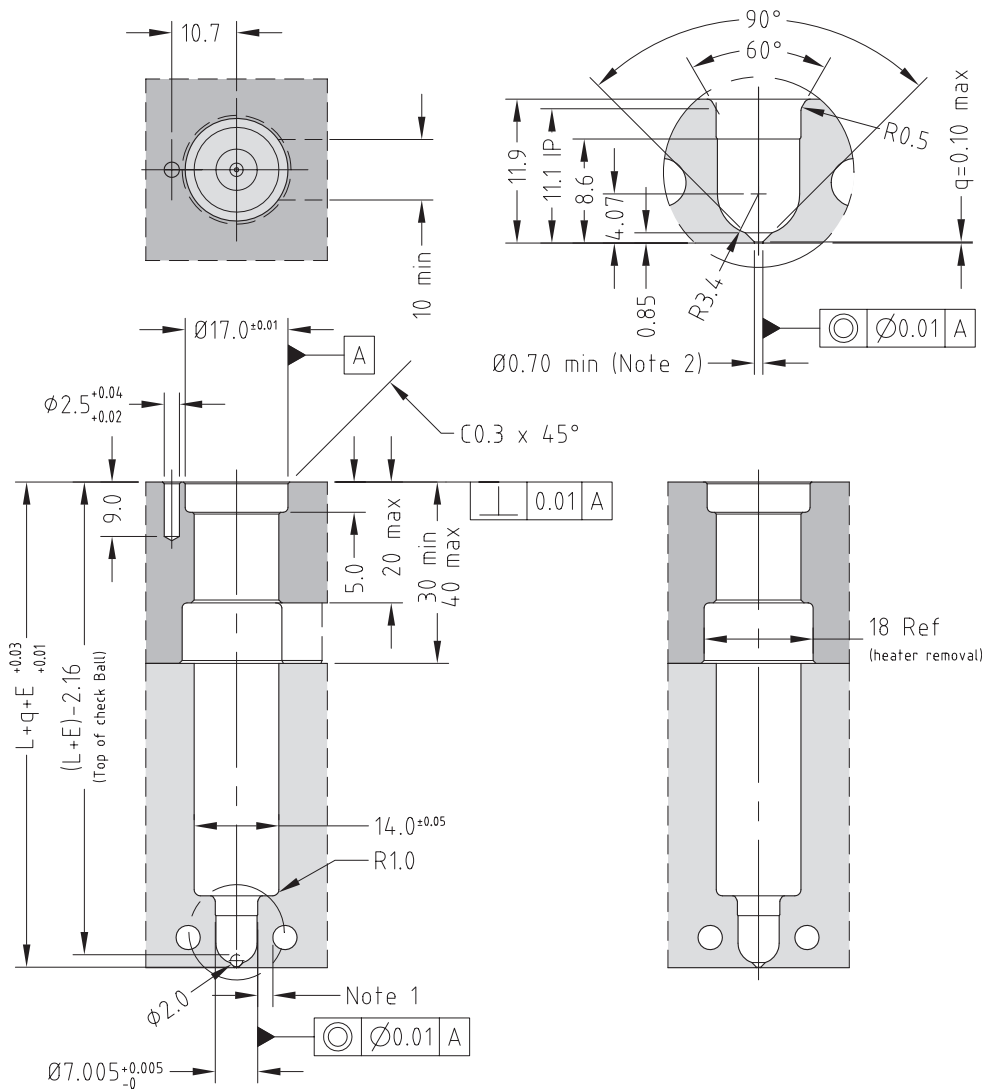

**Note**

- Gate cooling is critical for correct operation and gate quality. → See Cooling section in the Technical Specifications.
  - Modify gate diameter and land to suit the part. → See Gate Modifications in the Technical Specifications.
- \* Minimum strength ( $\sigma_y$ ) of nozzle plate 800MPa.

Tip and Material Grade Availability

Tip (Code)	G1	G2	G5
Multi-hole Torpedo Tip (MJ 09 TT+10)	×	✓	×

**To order a nozzle assembly:**

Provide the Nozzle Code + Grade  
 (Order example: MJTT09075+10 G2)

**To order a tip:**

Provide the Tip Code + Grade  
 (Order example: MJ 09 TT+10 G2)

Nozzle Dimensions

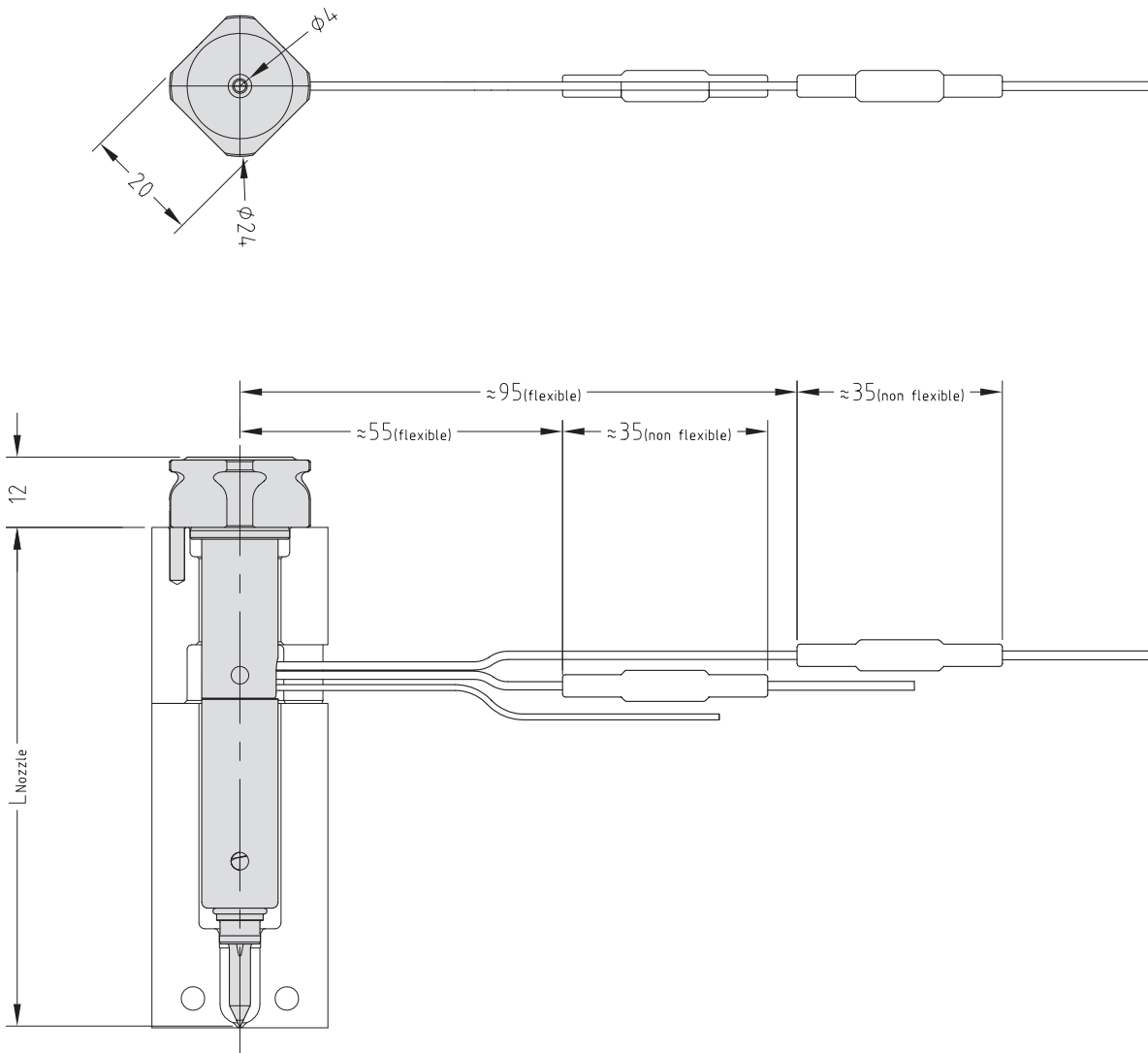



## Front Loading Configuration

## Pre Installation

The heaters and thermocouples should not be fitted to the nozzle prior to mould installation. For your safety leave the plastic protection cap on the nozzle.

## Installation

## ONE

Fit dowels into mould plate. Fit each nozzle body into the cavity plate. Check all nozzles are level within 0.02mm.

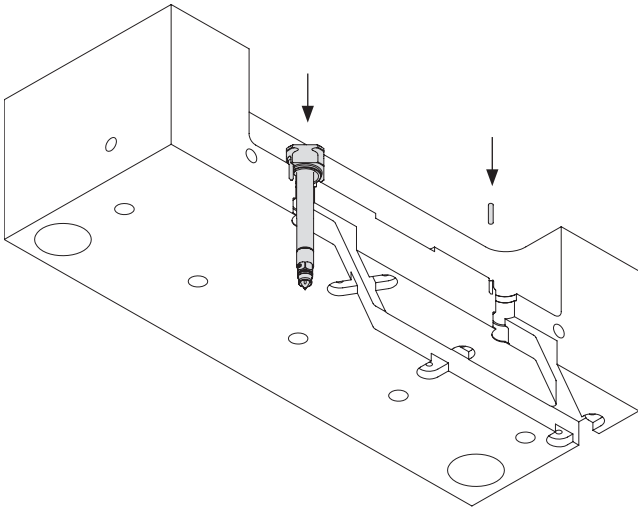

## TWO

Slide heaters onto nozzles with fixed cover towards nozzle head. Take care not to compress heater coils at the tip end of the heater. Thread the wires through wire channels in the cavity plate.

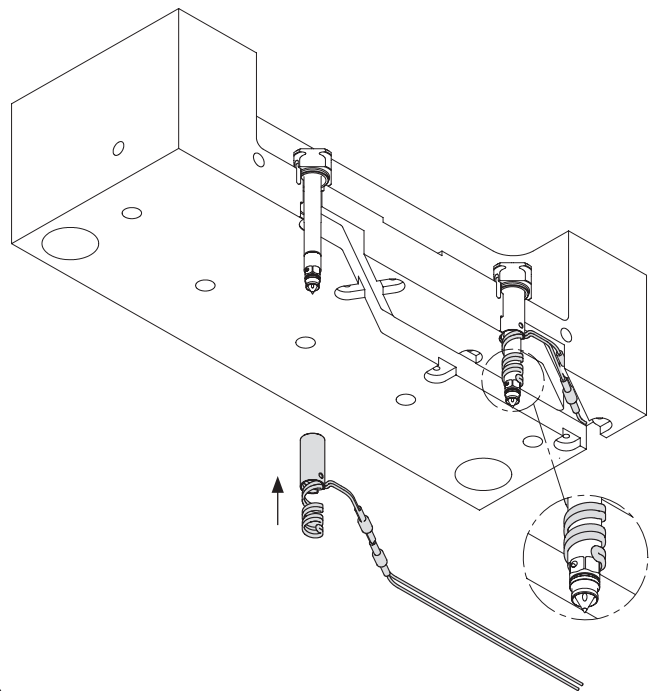

## THREE

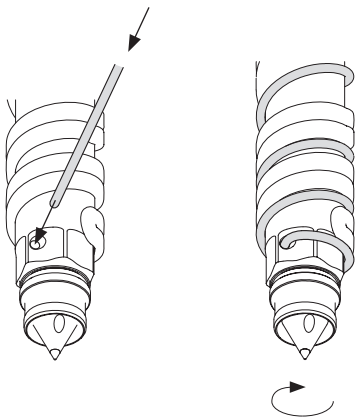

- a. Slide thermocouple probe into the thermocouple hole in tip.
- b. Holding thermocouple probe secure in hole, wind thermocouple around tip above heater coil in a clockwise direction to the gap between heater coils. To ensure probe is held secure there should be as near to 1 full wind to the gap.
- c. Wind thermocouple down nozzle between heater coils, keeping the thermocouple tight against the nozzle body.
- d. When the heater wire exit is reached thread wires through wire channel with the heater wires.

## FOUR

- a. Fit heater top cover. As the cover slides over the heater and thermocouple rotate cover, taking care not to compress heater or damage the thermocouple.
- b. Fit snap ring.

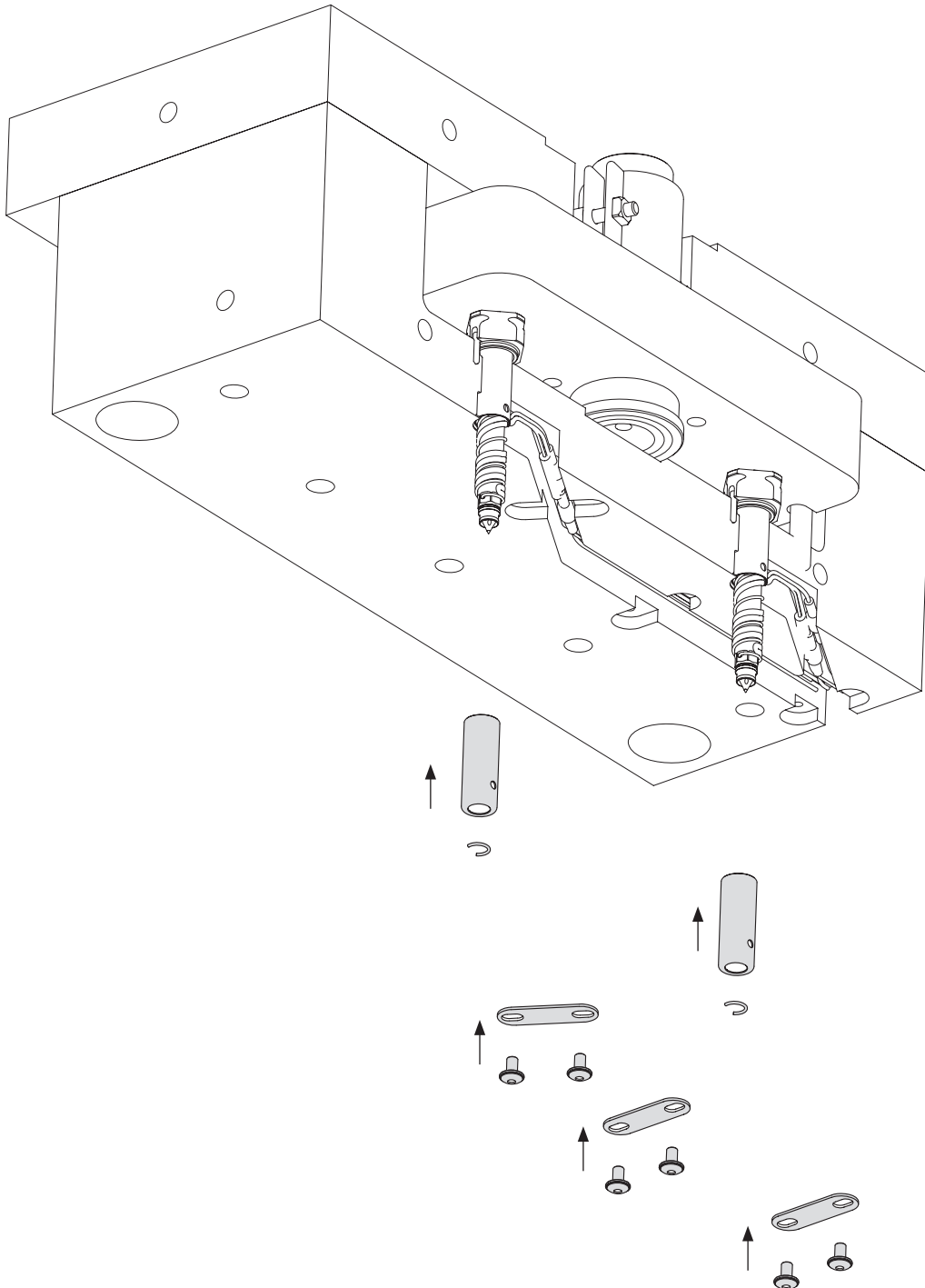

## Rear Loading Configuration

### Pre Installation

The heaters and thermocouples should not be fitted to the nozzle prior to mould installation.  
For your safety leave the plastic protection cap on the nozzle.

### Installation

**ONE**

Slide the heaters onto the nozzles with the fixed cover towards the nozzle head. Take care not to compress the heater coils at the tip end of the heater.

**TWO**

Fit the thermocouple.

**THREE**

Fit the heater top cover. As the cover slides over the heater and T/C rotate the cover, taking care not to compress the heater or damage the T/C.

**FOUR**

Fit the snap ring.

**FIVE**

Fit the dowels into the mould plate.

**SIX**

One by one fit the nozzle assemblies into the nozzle cavity plate. Check that all nozzles are level within 0.02mm.

**SEVEN**

Fasten the wires in the cavity plate.

## Replacing the Tip &amp; Seal Assembly

## ONE

- Remove snap ring
- Remove heater cover

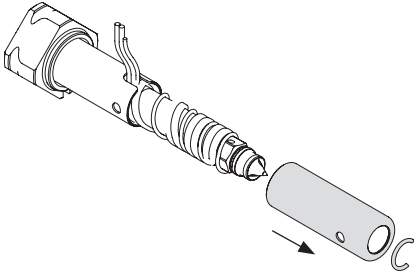

## TWO

Remove thermocouple from nozzle

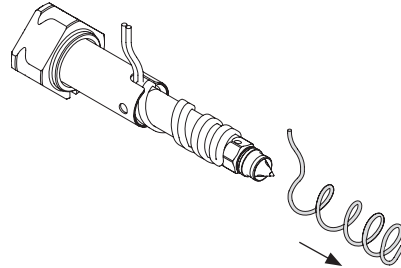

## THREE

Remove heater.  
Using an AF8mm deep socket unscrew tip from body

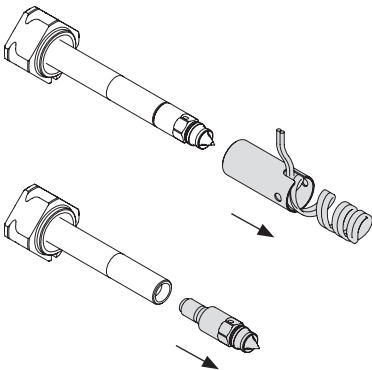

## FOUR

- Clean any plastic & debris from the tip pocket in nozzle body.
- Smear a small amount of anti-seize around new tip thread.
- Screw new tip into the body and torque to 4Nm (3lb ft). **Warning: Do not overtighten.**
- Fit the heater, thermocouple, heater cover & snap ring.

## Replacing the Thermocouple

## ONE

- Remove snap ring
- Remove heater cover

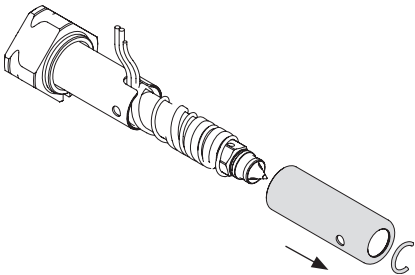

## TWO

Remove existing thermocouple from the nozzle

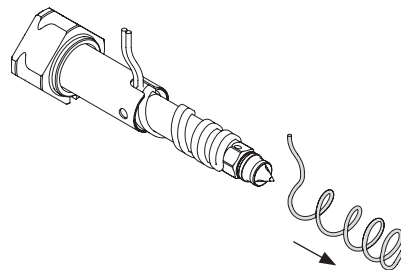

## THREE

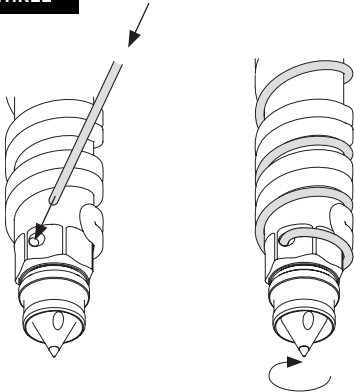

- a. Slide thermocouple probe into thermocouple hole in tip.
- b. Holding thermocouple probe secure in the hole, wind thermocouple around tip above heater coil in a clockwise direction to the space between the heater coils. To ensure the probe is held secure the space between the heater coils should be equivalent to 1 full wind of the thermocouple.
- c. Wind thermocouple down nozzle between the heater coils, keeping thermocouple tight against the nozzle body.
- d. When heater wire exit is reached thread the wires through wire channel with heater wires.

## FOUR

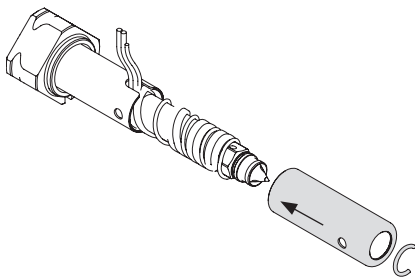

Fit heater cover and snap ring.

## Replacing the Heater

## ONE

- a. Remove heater cover and snap ring.
- b. Remove thermocouple.
- c. Holding heater at the base slightly twist the top heater coils in a clockwise direction and pull the heater from the nozzle body.
- d. Clean any plastic or debris from the nozzle body.
- e. Slide the new heater onto the nozzle body, ensuring the top coil of heater reaches the bottom of the tip hex.
- f. Fit thermocouple, heater cover and snap ring.



**Mastip Head Office New Zealand**

558 Rosebank Road  
Avondale, PO Box 90-651  
Auckland, New Zealand  
Phone: +64 9 970 2100  
Fax: +64 9 970 2070  
Email: mastip@mastip.com

**Mastip Regional Office Europe**

Phone: +33 4 724 72 800  
Fax: +33 4 724 72 801  
Email: europe@mastip.com

**Mastip Regional Office China**

Phone: +86 21 644 77838  
Fax: +86 21 644 77828  
Email: china@mastip.com

**Mastip Regional Office North America**

Phone: +1 262 644 9400  
Fax: +1 262 644 9402  
Email: northamerica@mastip.com

40-000-110 V1.04

