

MXVG13



smart hot runner solutions

www.mastip.com

Tip and Material Grade Availability

Tip (Code)	G1	G2	G5
One-hole Torpedo Tip	×	×	×
Open Tip (X 13 OV)	✓	×	×

To order a nozzle assembly:
provide the Nozzle Code + Grade
(Order example: MXOV13145 G1)

To order a tip:
provide the Tip Code + Grade
(Order example: X 13 OV G1)

Nozzle Dimensions

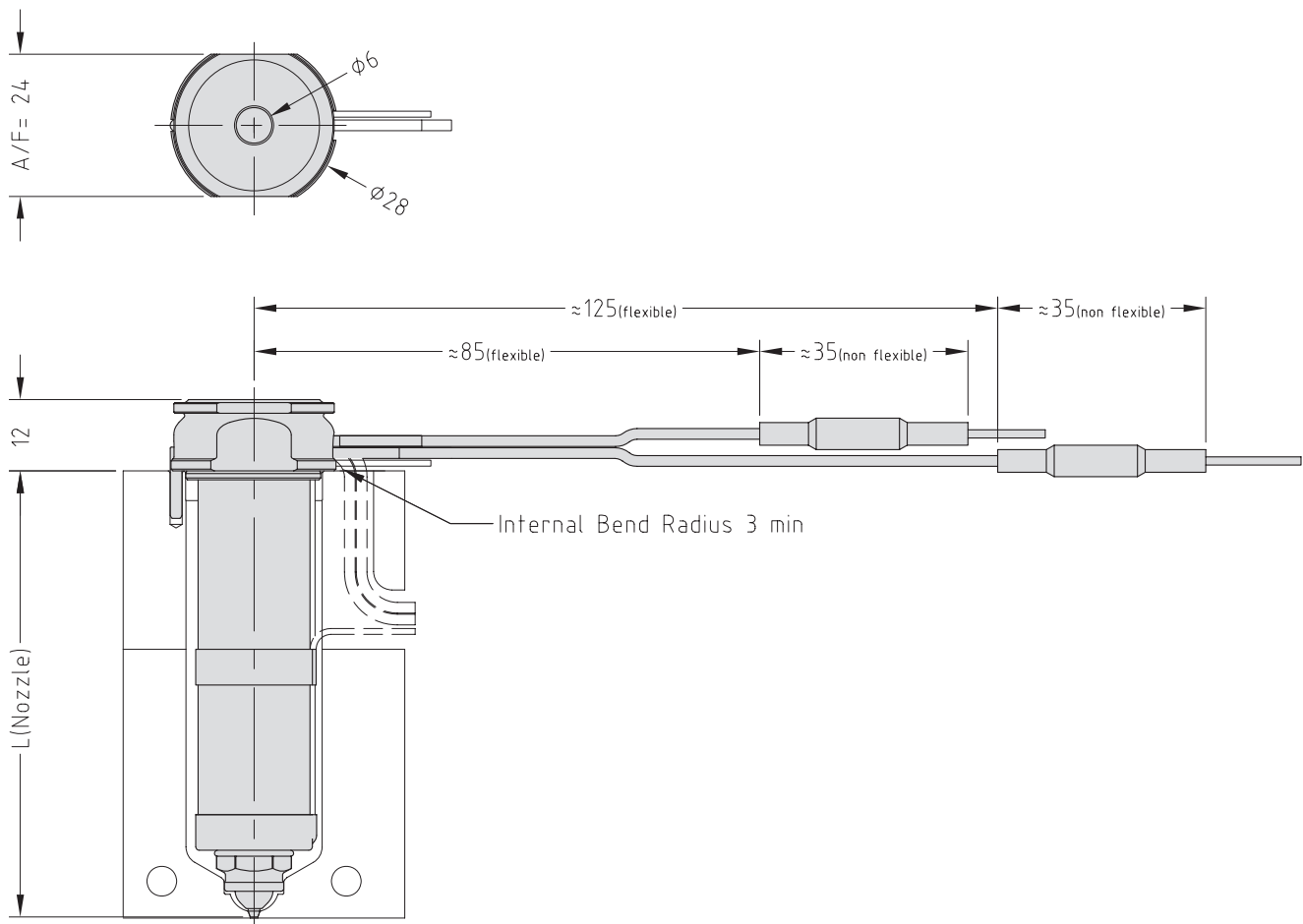

Note

* Pins are supplied $\phi 2.0 \times 250$ and must be cut to required length and taper added by mould maker at time of installation.

Mastip Head Office New Zealand

558 Rosebank Road
Avondale 1026, Auckland
PO Box 90-651
Victoria Street West
Auckland 1142
New Zealand
Phone: +64 9 970 2100
Fax: +64 9 970 2070
Email: mastip@mastip.com

Mastip Regional Office Europe

Phone: +33 4 724 72 800
Fax: +33 4 724 72 801
Email: europe@mastip.com

Mastip Regional Office China

Phone: +86 21 644 77838
Fax: +86 21 644 77828
Email: china@mastip.com

Mastip Regional Office North America

Phone: +1 262 644 9400
Fax: +1 262 644 9402
Email: northamerica@mastip.com

40-000-004

V1.04



MXVG16



smart hot runner solutions

www.mastip.com

Tip and Material Grade Availability

Tip (Code)	G1	G2	G5
Multi-hole Torpedo Tip (X 16 TV)	×	×	×
One-hole Torpedo Tip	✓	×	×
Open Tip (X 16 OV)	✓	×	×

To order a nozzle assembly:

Provide the Nozzle Code + Grade
(Order example: MXTV16175 G1)

To order a tip:

Provide the Tip Code + Grade
(Order example: X 16 TV G1)

Nozzle Dimensions

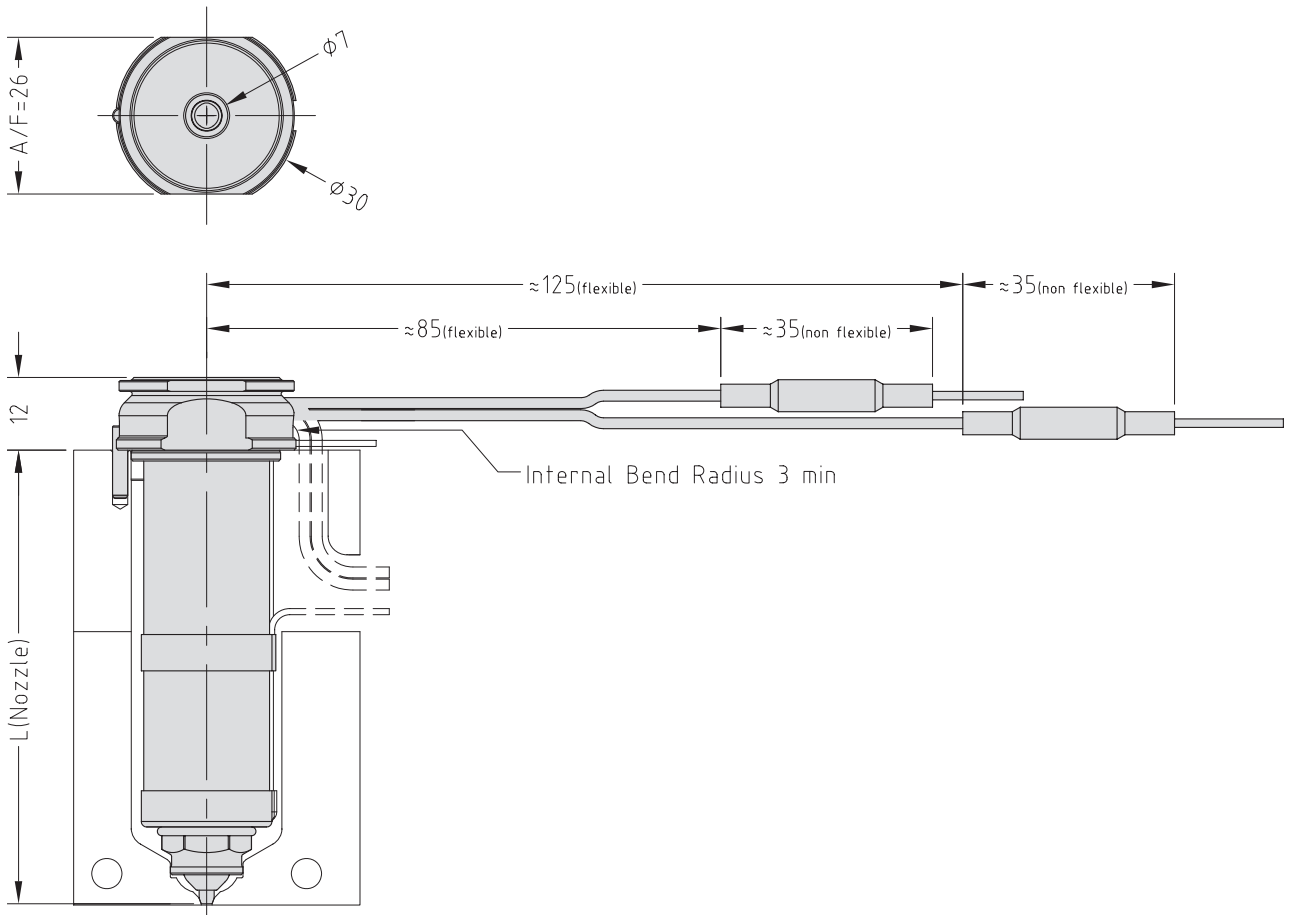

Note

* Pins are supplied $\phi 2.5 \times 250$ and must be cut to required length and taper added by mould maker at time of installation.

Tip and Material Grade Availability

Tip (Code)	G1	G2	G5
Multi-hole Torpedo Tip (X 16 TV)	✓	✗	✗
One-hole Torpedo Tip	✗	✗	✗
Open Tip (X 16 OV)	✓	✗	✗

To order a nozzle assembly:

Provide the Nozzle Code + Grade
(Order example: MXOVBE16175 G1)

To order a tip:

Provide the Tip Code + Grade
(Order example: X 16 TV G1)

Nozzle Dimensions

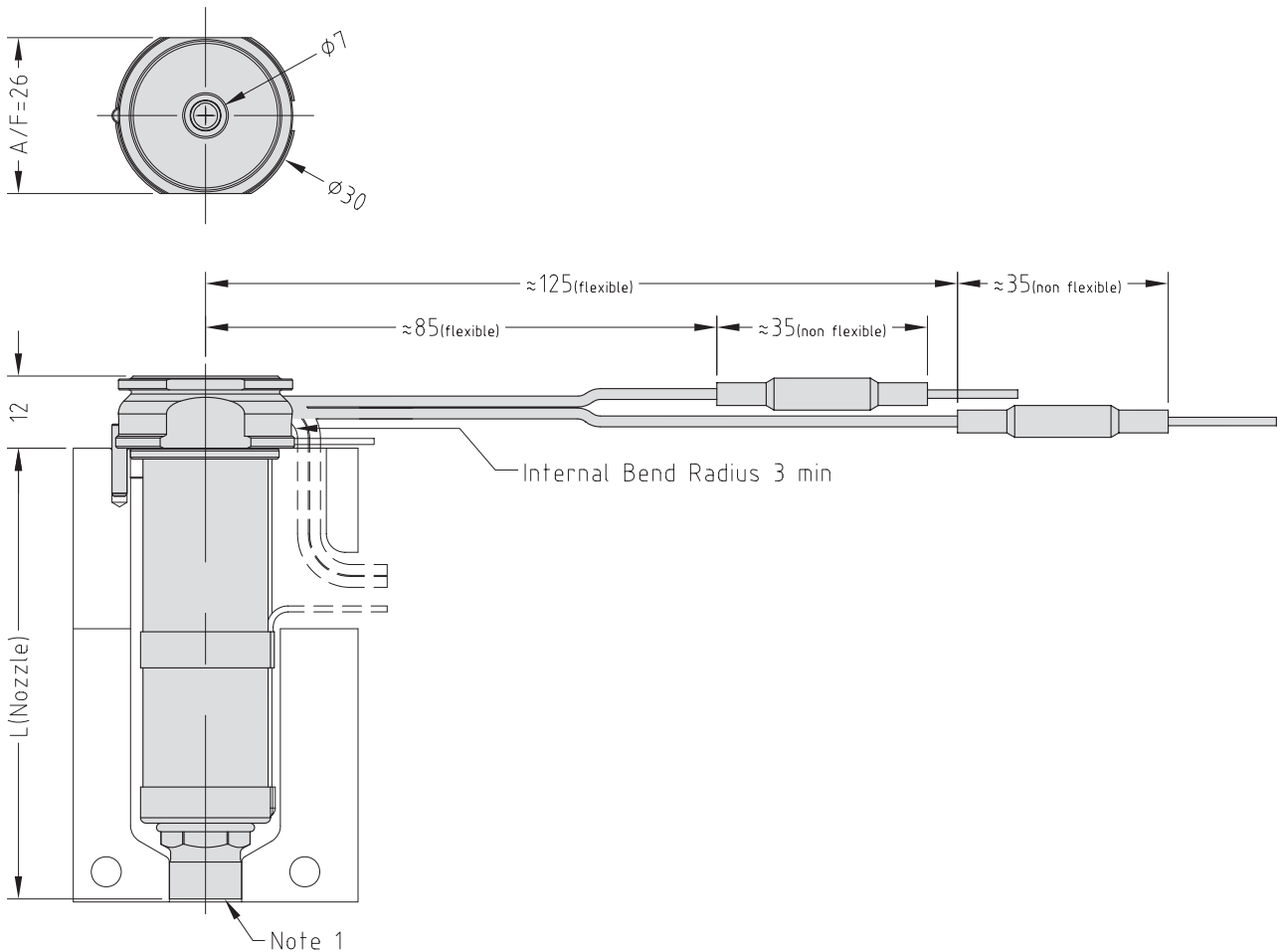

Note

1. Modify the contact area to suit the application.
→ See Gate Modifications and Cooling sections in the Technical Specifications.
- * Pins are supplied $\phi 2.5 \times 250$ and must be cut to required length and taper added by mould maker at time of installation.

Tip and Material Grade Availability

Tip (Code)	G1	G2	G5
Multi-hole Torpedo Tip (X 16 TV)	✓	×	×
One-hole Torpedo Tip	×	×	×
Open Tip (X 16 OV)	✓	×	×

To order a nozzle assembly:

Provide the Nozzle Code + Grade
(Order example: MXTVSN16175 G1)

To order a tip:

Provide the Tip Code + Grade
(Order example: X 16 TV G1)

Nozzle Dimensions

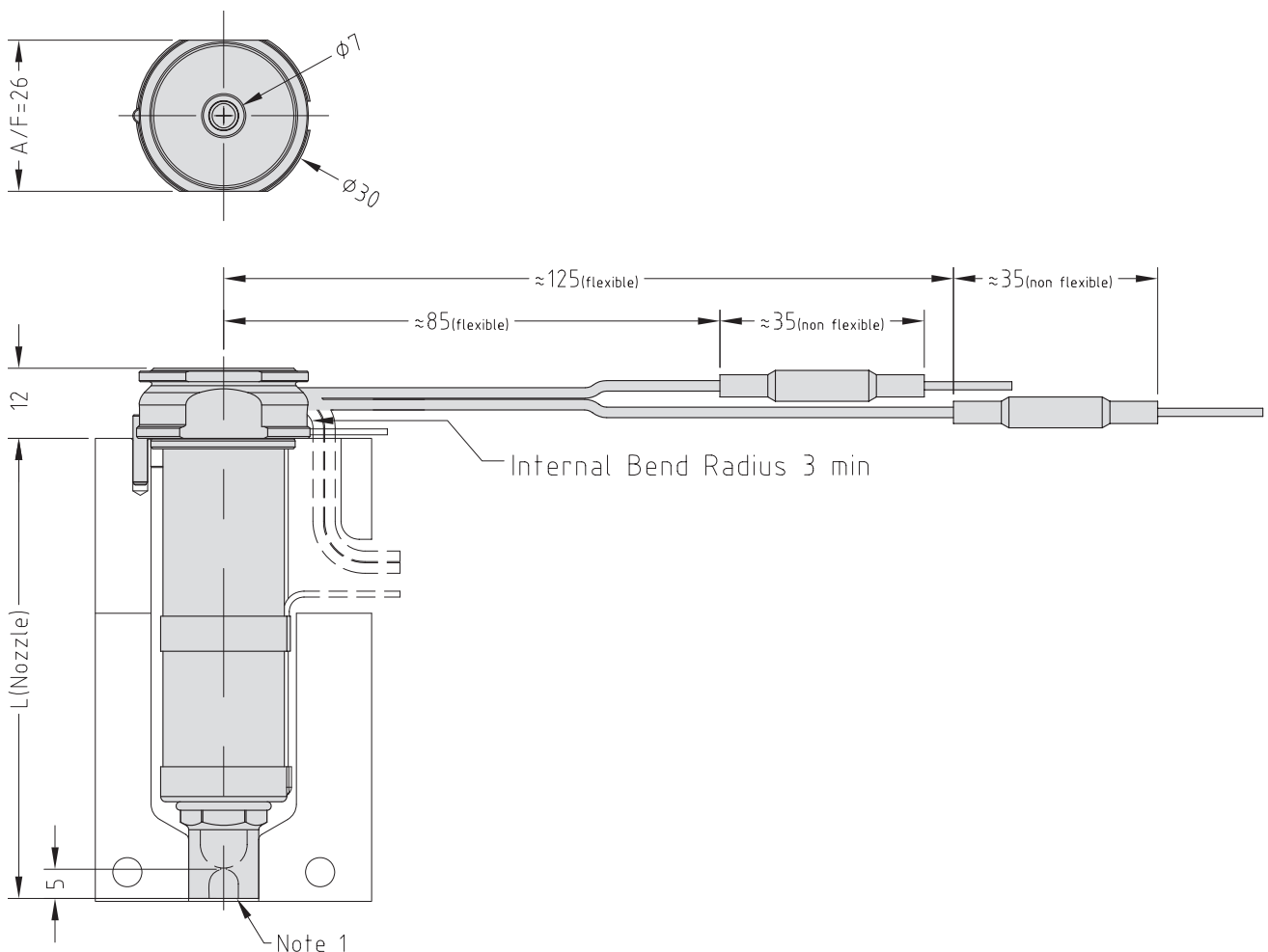
**Note**

1. Modify the contact area and the sprue nut to suit the application.
→ See Gate Modifications and Cooling sections in the Technical Specifications.
- * Pins are supplied $\phi 2.5 \times 250$ and must be cut to required length and taper added by mould maker at time of installation.

Mastip Head Office New Zealand

558 Rosebank Road
Avondale 1026, Auckland
PO Box 90-651
Victoria Street West
Auckland 1142
New Zealand
Phone: +64 9 970 2100
Fax: +64 9 970 2070
Email: mastip@mastip.com

Mastip Regional Office Europe

Phone: +33 4 724 72 800
Fax: +33 4 724 72 801
Email: europe@mastip.com

Mastip Regional Office China

Phone: +86 21 644 77838
Fax: +86 21 644 77828
Email: china@mastip.com

Mastip Regional Office North America

Phone: +1 262 644 9400
Fax: +1 262 644 9402
Email: northamerica@mastip.com

40-000-014

V1.04



MXVG19



smart hot runner solutions

www.mastip.com

Tip and Material Grade Availability

Tip (Code)	G1	G2	G5
Multi-hole Torpedo Tip (X 19 TV)	✓	×	×
One-hole Torpedo Tip	×	×	×
Open Tip (X 19 OV)	✓	×	✓

To order a nozzle assembly:

Provide the Nozzle Code + Grade
(Order example: MXOV19175 G1)

To order a tip:

Provide the Tip Code + Grade
(Order example: X 19 TV G1)

Nozzle Dimensions

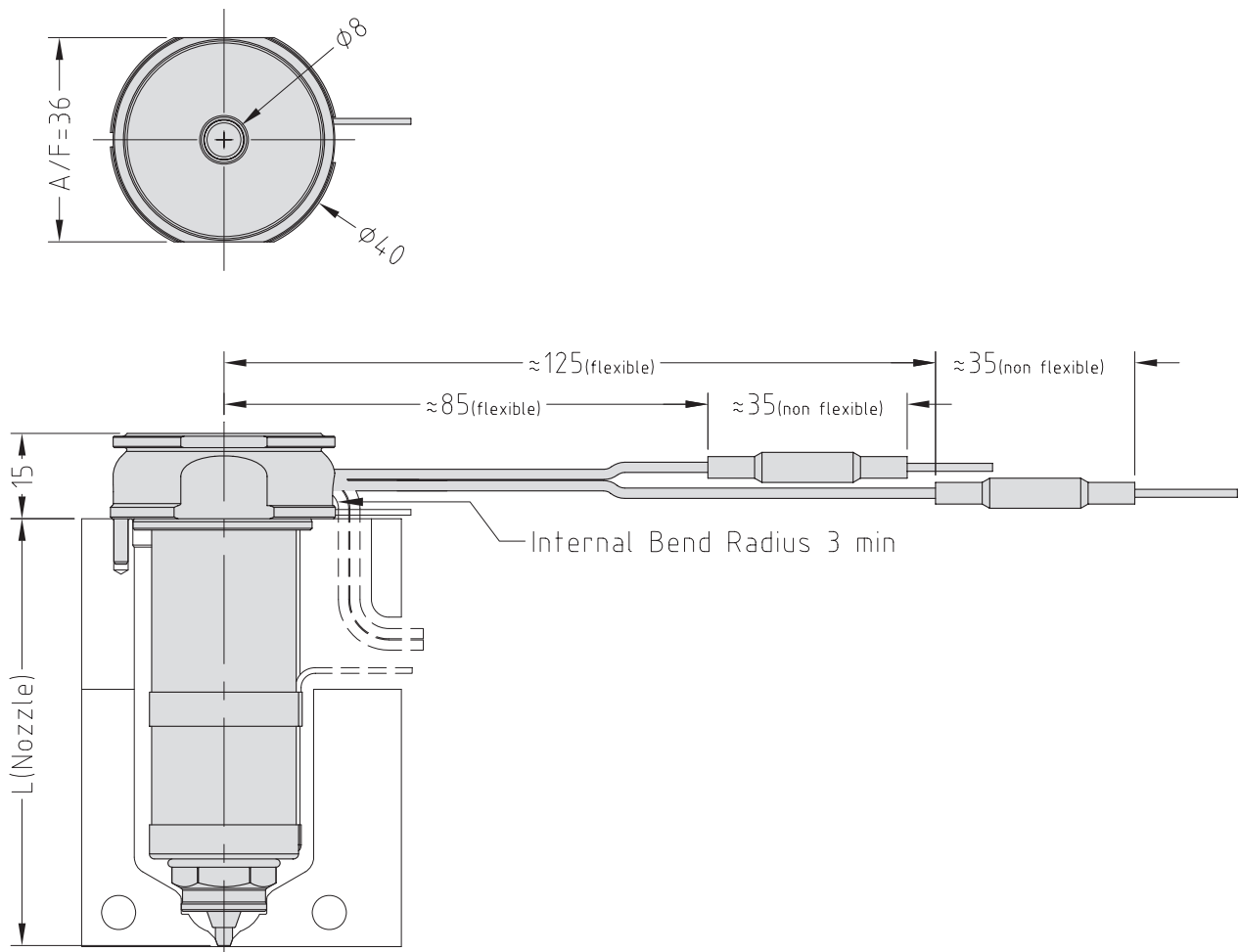
**Note**

* Pins are supplied $\text{Ø}3.0 \times 250$ and must be cut to required length and taper added by mould maker at time of installation.

Order Code & Expansion

Multi-Hole Torpedo Nozzle Code	Open Tip Nozzle Code	L	E@ΔT =200C	E@ΔT =250C
MXTV19055	MXOV19055	55	0.15	0.18
MXTV19065	MXOV19065	65	0.17	0.21
MXTV19075	MXOV19075	75	0.20	0.25
MXTV19095	MXOV19095	95	0.25	0.31
MXTV19115	MXOV19115	115	0.30	0.38
MXTV19145	MXOV19145	145	0.38	0.48

Valve Gate Assembly

Order Code	Actuation Type	Pin Size	Stroke
MVCH2510-3.0	Hydraulic	3	10
MVG40-3.0x250	Pneumatic	3	10

One Valve Gate assembly is required per nozzle

Nozzle Fitment and Gate Dimensions

$$E = L \times 0.000132 \times (\text{nozzle temp. } ^\circ\text{C} - \text{mould temp. } ^\circ\text{C})$$

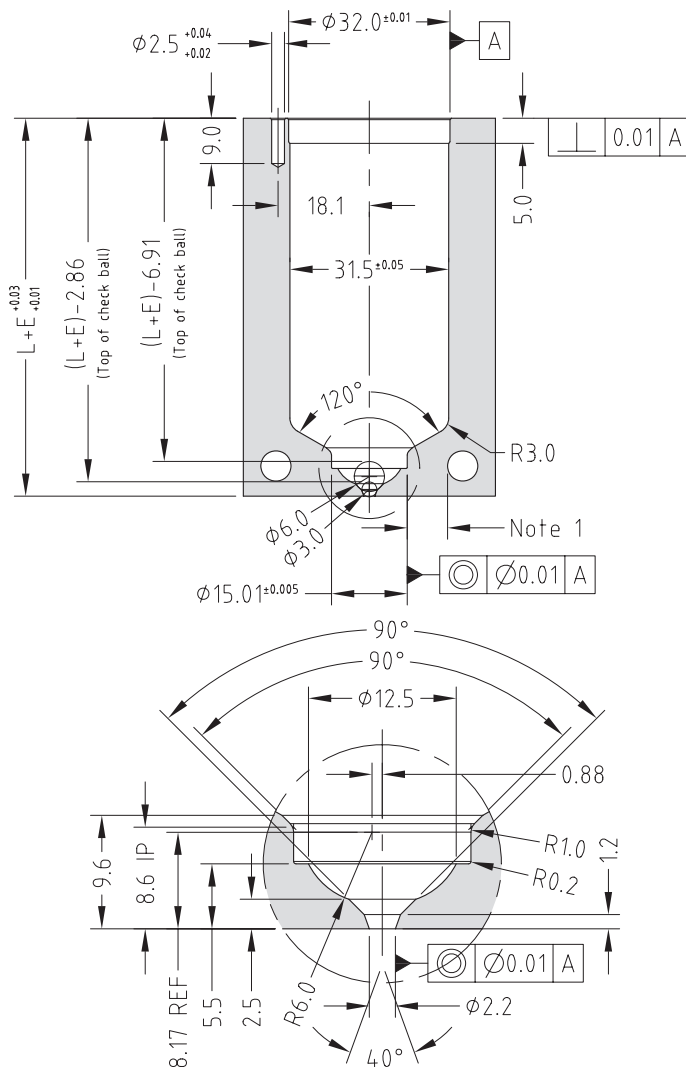

Hot Half Configuration

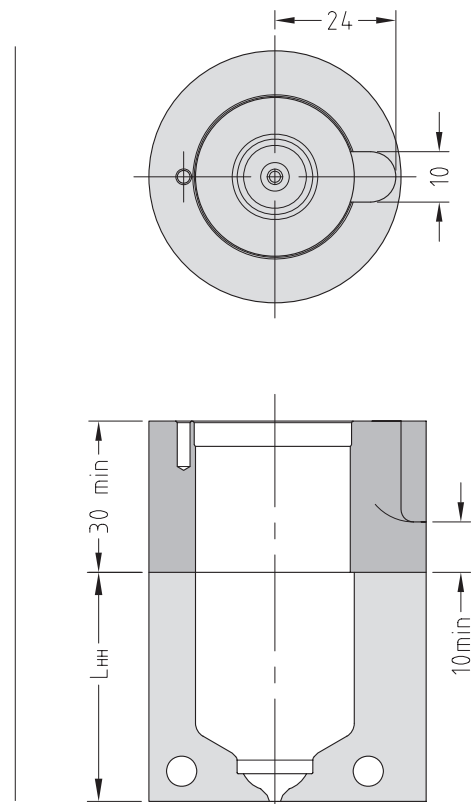

Note

1. Gate cooling is critical for correct operation and gate quality. → See Cooling Section in the Technical Specifications.

* Minimum strength (σ_y) of nozzle plate 800MPa.

Tip and Material Grade Availability

Tip (Code)	G1	G2	G5
Multi-hole Torpedo Tip (X 19 TV)	✓	✗	✗
One-hole Torpedo Tip	✗	✗	✗
Open Tip (X 19 OV)	✓	✗	✓

To order a nozzle assembly:

Provide the Nozzle Code + Grade
(Order example: MXOVBE19175 G1)

To order a tip:

Provide the Tip Code + Grade
(Order example: X 19 TV G1)

Nozzle Dimensions

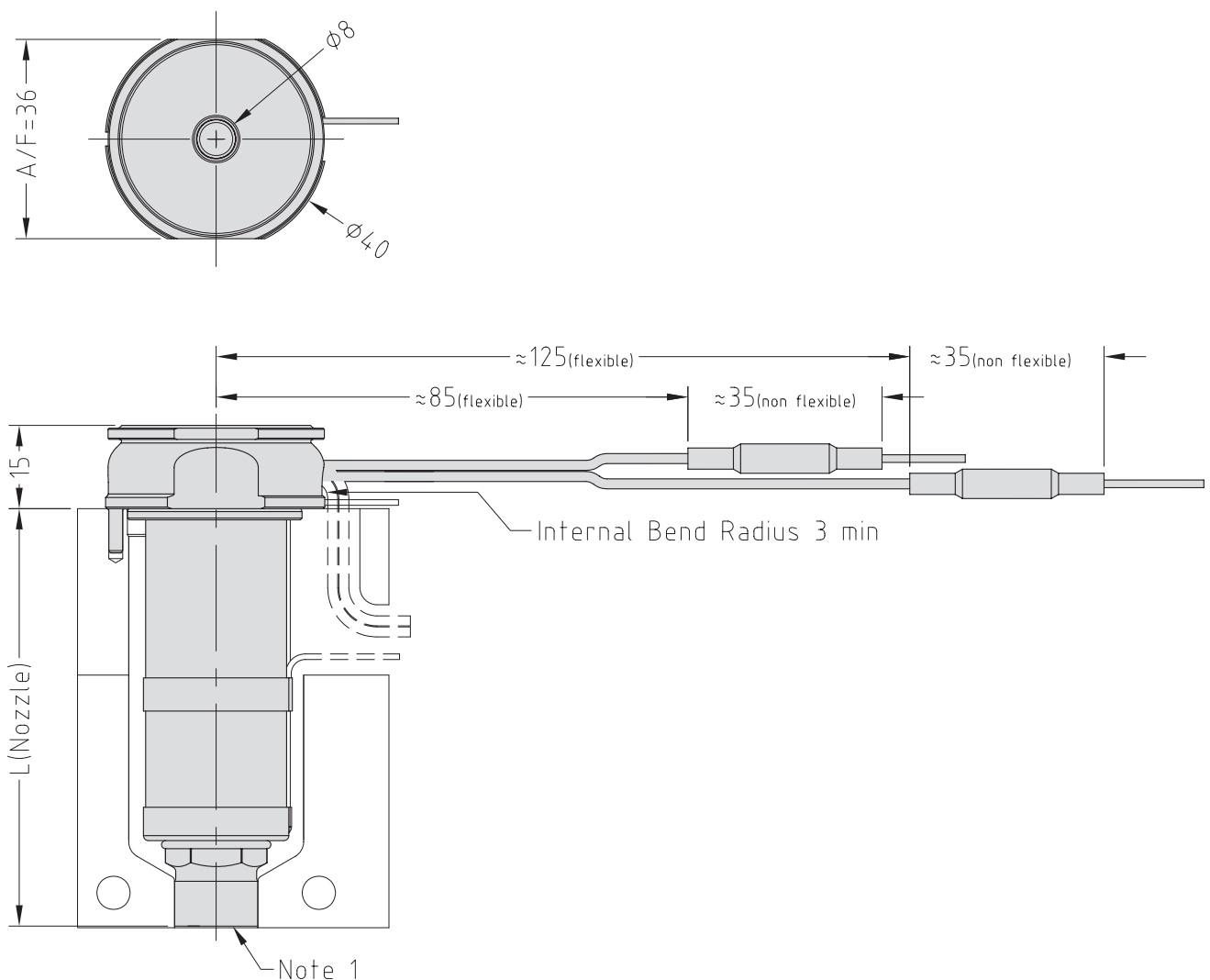

Note

1. Modify the contact area to suit the application.
 → See Gate Modifications and Cooling sections in the Technical Specifications.
- * Pins are supplied $\phi 3.0 \times 250$ and must be cut to required length and taper added by mould maker at time of installation.

Tip and Material Grade Availability

Tip (Code)	G1	G2	G5
Multi-hole Torpedo Tip (X 19 TV)	✓	×	×
One-hole Torpedo Tip	×	×	×
Open Tip (X 19 OV)	✓	×	✓

To order a nozzle assembly:

Provide the Nozzle Code + Grade
(Order example: MXTVSN19175 G1)

To order a tip:

Provide the Tip Code + Grade
(Order example: X 19 TV G1)

Nozzle Dimensions

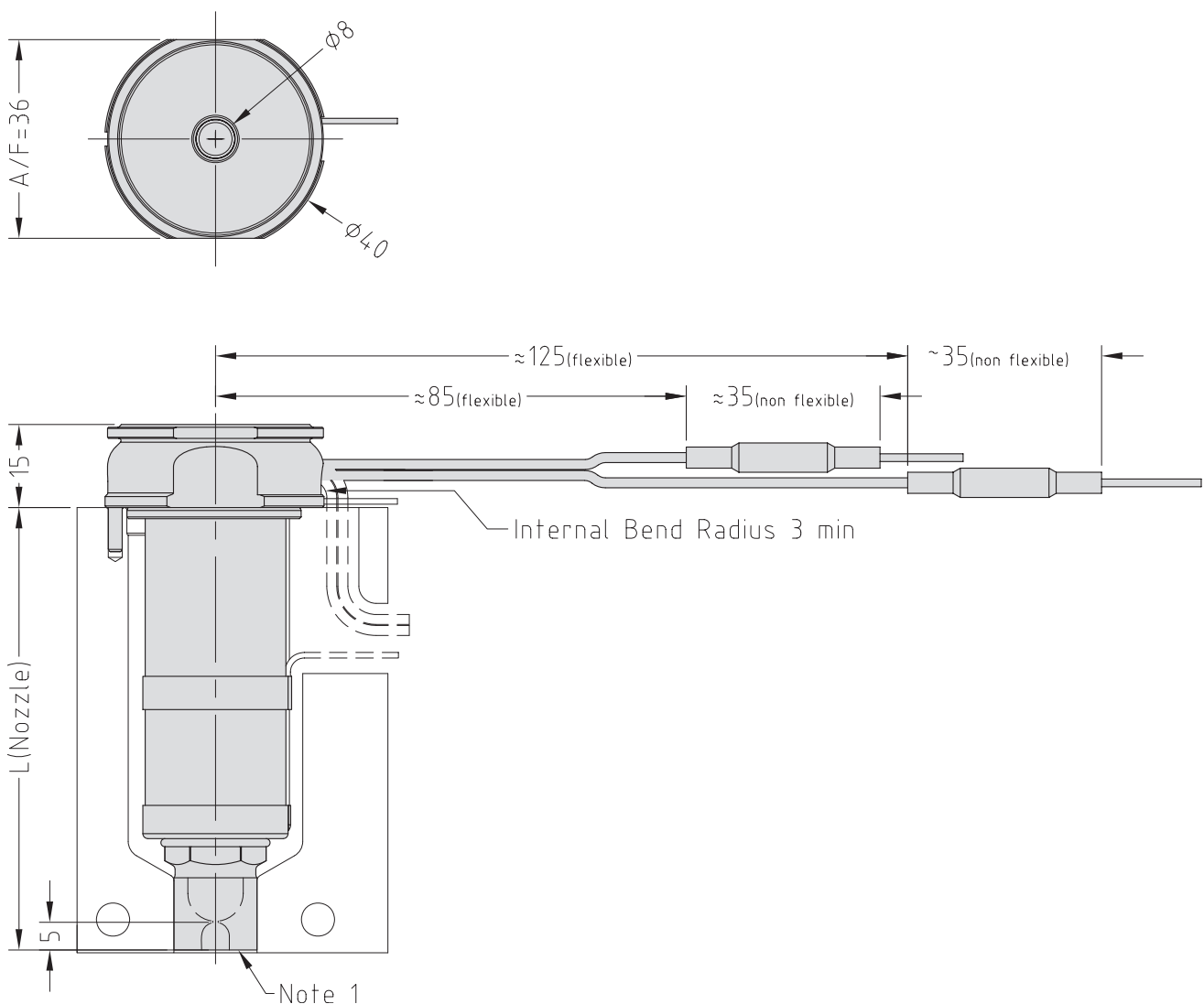
**Note**

1. Modify the contact area and the sprue nut to suit the application.

→ See Gate Modifications and Cooling sections in the Technical Specifications.

* Pins are supplied $\phi 3.0 \times 250$ and must be cut to required length and taper added by mould maker at time of installation.

Mastip Head Office New Zealand

558 Rosebank Road
Avondale 1026, Auckland
PO Box 90-651
Victoria Street West
Auckland 1142
New Zealand
Phone: +64 9 970 2100
Fax: +64 9 970 2070
Email: mastip@mastip.com

Mastip Regional Office Europe

Phone: +33 4 724 72 800
Fax: +33 4 724 72 801
Email: europe@mastip.com

Mastip Regional Office China

Phone: +86 21 644 77838
Fax: +86 21 644 77828
Email: china@mastip.com

Mastip Regional Office North America

Phone: +1 262 644 9400
Fax: +1 262 644 9402
Email: northamerica@mastip.com

40-000-024 V1.06

